

# 1000BASE-T TRANSFORMER MODULE

Ruggedized



- Compliant with IEEE 802.3ab standard
- 350uH OCL with 8mA DC
- Operating Temperature: -40°C to + 85°C
- Storage temperature: -55°C to + 125°C
- Epoxy encapsulated package withstands 235°C peak
- Moisture Sensitivity Level: 3
- Lead Finish: Sn63/Pb37

## Electrical Specifications @ 25°C

Part Number <sup>2</sup>	Insertion Loss (dB Min)	Return Loss (dB Max)				Crosstalk (dB Max)			CM to CM Rejection Ratio (dB Max)			DM to CM Rejection Ratio (dB Max)			HiPot (Vrms MIN)
		0.1-100 Mhz	30 MHz	60 MHz	80 Mhz	100 Mhz	30 Mhz	60 Mhz	100 Mhz	30 Mhz	60 Mhz	100 Mhz	30 Mhz	60 Mhz	
1000B-5016	-1.20	-18	-12	-12	-10	-43	-37	-31	-30	-23	-17	-40	-35	-30	1500

Note: 1. Add suffix NL for RoHS compliant part; i.e. 1000B-5016, becomes 1000B-5016NL.  
 2. For Tape and Reel Packaging, add "T" suffix at the end of the part number; i.e. 1000B-5016T

## Mechanical

### 1000B-5016

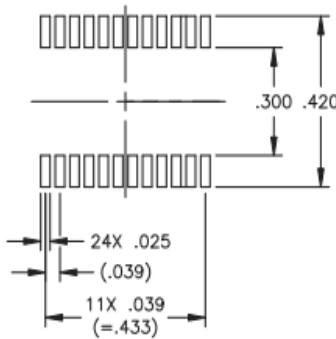
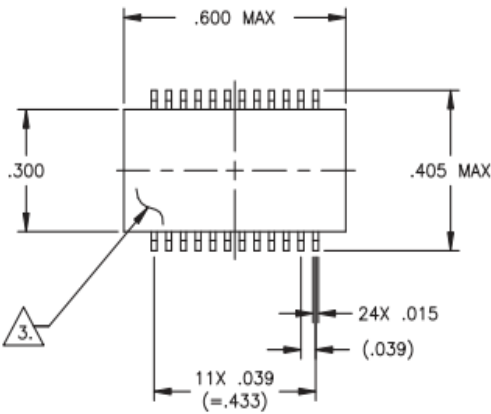

Weight ..... 0.75 grams  
 Tape and Reel ..... .700/reel  
 Tube ..... 30/tube

Dimensions: Inches  
 mm  
 Unless otherwise specified,  
 all tolerances are ± .010  
 0,25

SUGGESTED LAND PATTERN

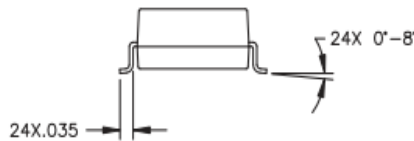
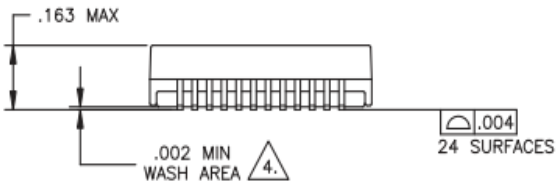

## Electrical Schematic

1000B-5016

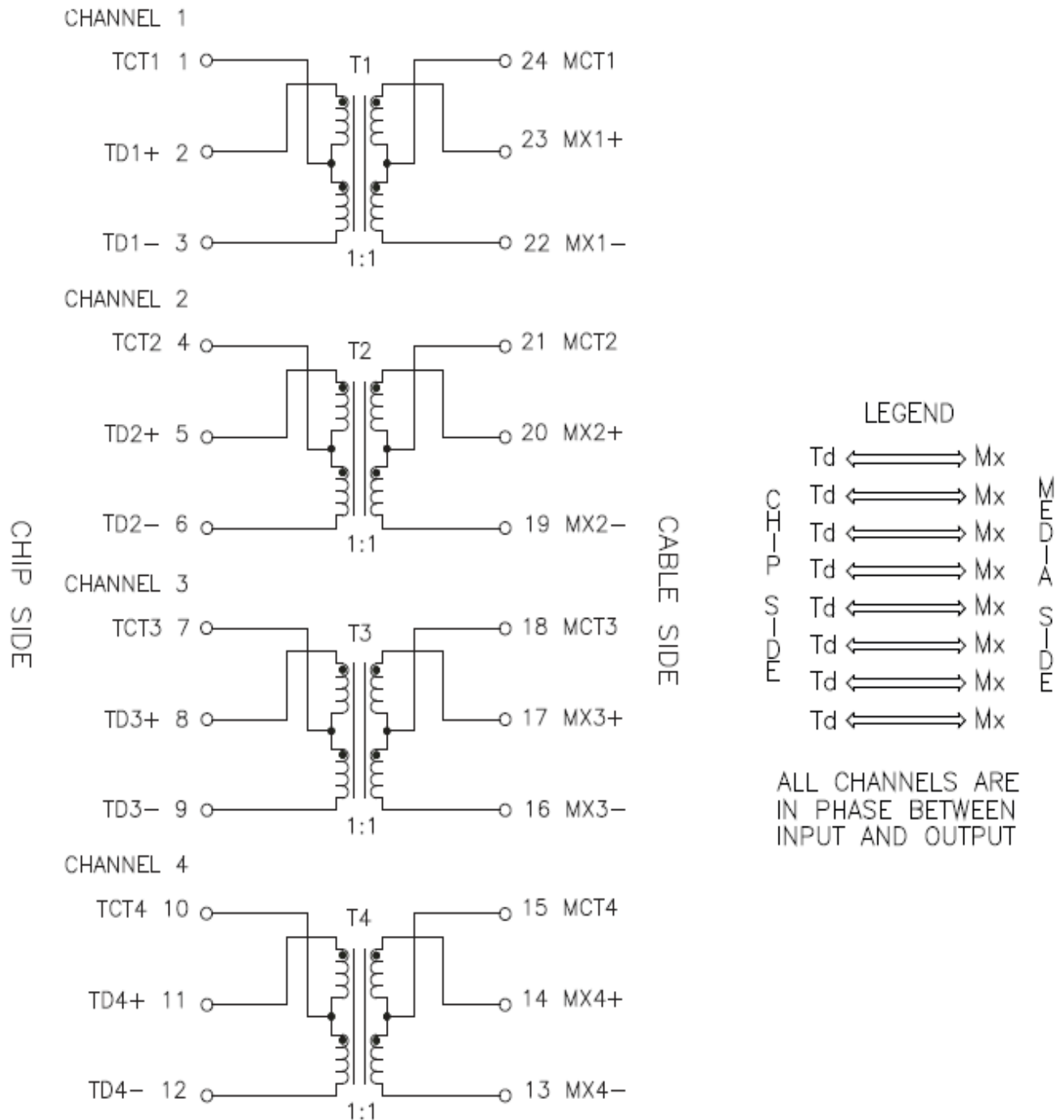

## Tin/Lead Recommended Reflow Profile (Based on J-STD-020D)

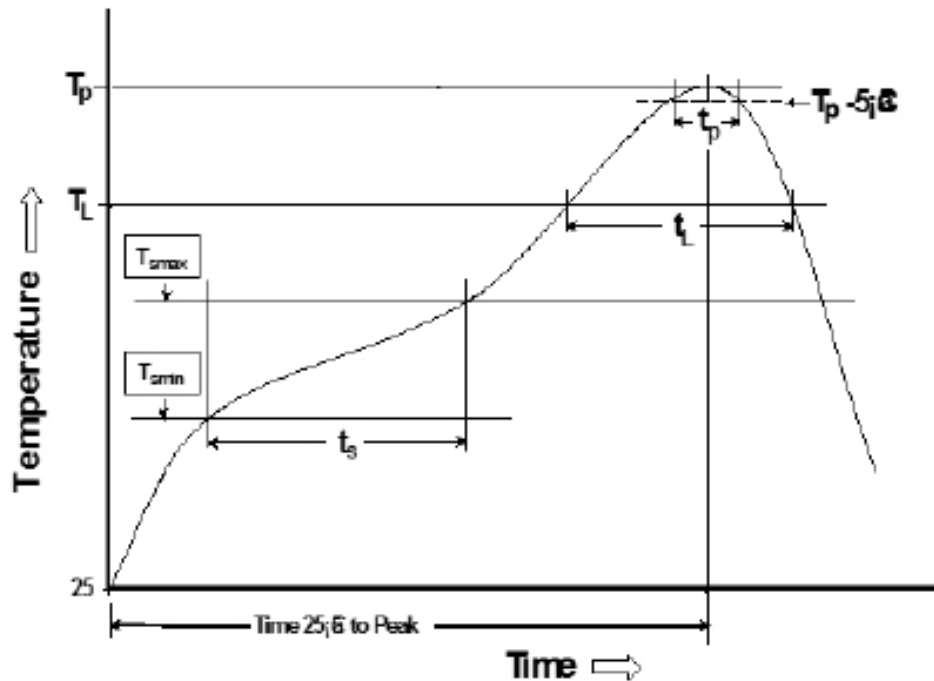

$T_{SMIN}$ (°C)	$T_{SMAX}$ (°C)	$T_L$ (°C)	$T_P$ (°C MAX)	$t_s$ (s)	$t_L$ (s)	$t_p$ (s MAX)	Ramp-up rate ( $T_L$ to $T_P$ )	Ramp-down rate ( $T_P$ to $T_L$ )	Time 25°C to peak temperature (s MAX)
100	150	183	235	60-120	60-150	20	3°C/s MAX	6°C/s MAX	360

Notes:

1. All temperatures measured on the package leads.
2. Maximum times of reflow cycle: 2.

### For More Information

PulseR North America  
Headquarters  
Two Pearl Buck Court  
Bristol, PA 19007  
U.S.A.

For Global Sales Representatives and Locations Visit:  
<http://www.pulseruggedized.com>

Tel: +1.215.781.6400  
Fax: +1.215.781.6403

Performance warranty of products offered on this data sheet is limited to the parameters specified. Data is subject to change without notice. Other brand and product names mentioned herein may be trademarks or registered trademarks of their respective owners. © Copyright, 2018, PulseR, LLC. All rights reserved.